

40-300 Checking vehicle level on front and rear axle

Preliminary work:
General background on chassis alignment check (40-0200)
Positioning of wheels (40-0210)

A. Front axle

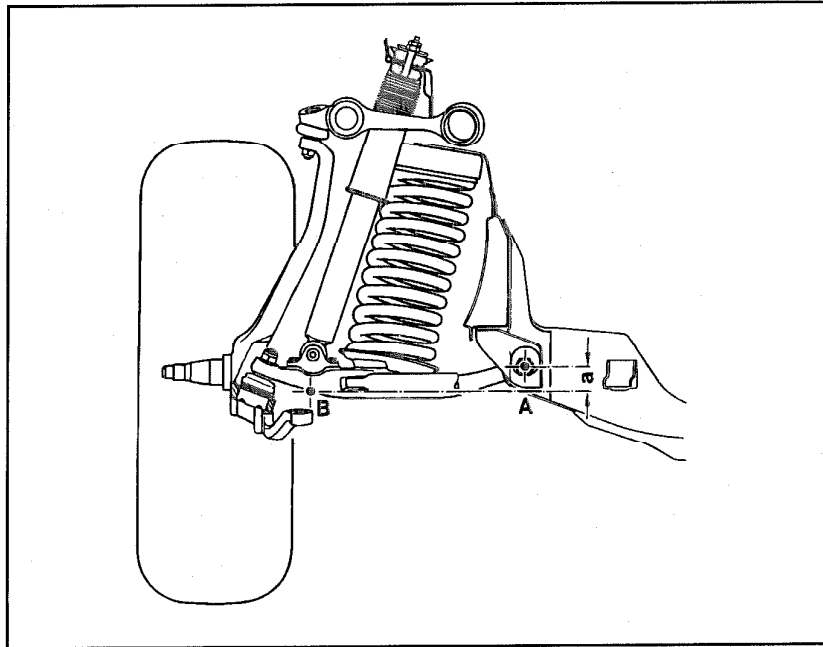

P40-0118-35

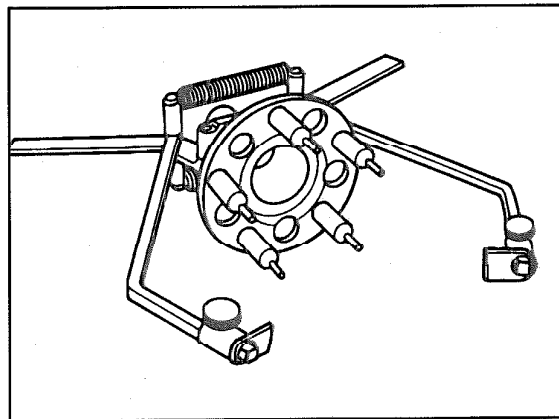

P40-2303-13

Vehicle level (control arm position) check with measuring device (01)

123 589 03 21 00, see data.

If vehicle level is within limit range of specified tolerances, find mean value of vehicle level (control arm position) to judge whether or not a correction is required. .

40-300 Checking vehicle level on front and rear axle

- a) Pull front end approx. 30 mm down and release, then measure vehicle level (control arm position).
- b) Push front end approx. 30 mm upward and release, then measure vehicle level (control arm position).
- c) Determine mean value of vehicle level (control arm position) from both measurements

Example:

Control arm position

Nominal value	= 56	+ 10	- 15	mm
after pulling downwards	= 52			mm
after pushing upwards	= 60			mm
mean value	= 56			mm

If the measured value lies beyond the tolerance, vehicle level

is adjusted by changing the installation height of the springs (32-200, 32-220).

Lighting systems

adjust (82-040).

B. Rear axle

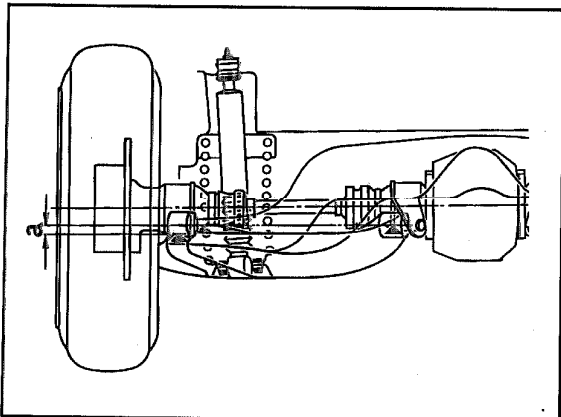

P40-0172-13

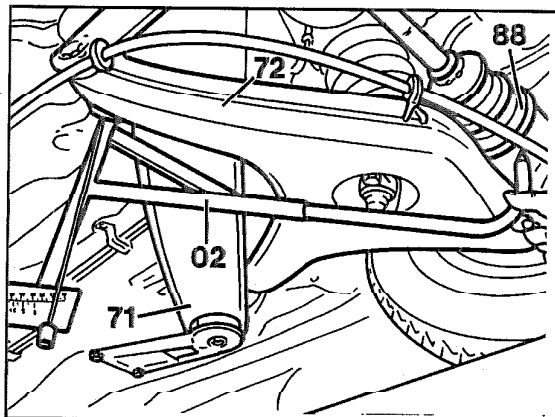

P40-2286-13

Diagonal swing axle

Difference in height axis inner semi-trailing arm bearing (A) – bottom edge cup for outer constant velocity joint (B)

40-300 Checking vehicle level on front and rear axle

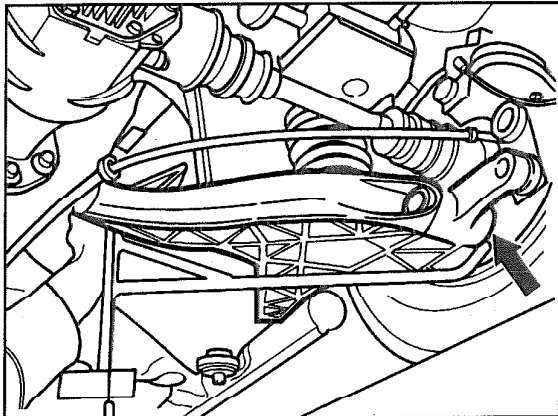

P40-2227-13

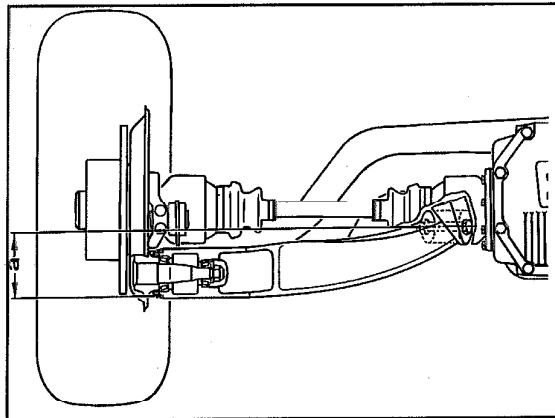

P40-0113-13

Diagonal swing axle with starting torque compensation

a = Difference in height axis inner semi-trailing arm bearing (A) – bottom edge protective ring of wheel carrier bearing of semi-trailing arm (B)

Vehicle level (semitrailing arm position) check with measuring device 107 589 01 21 00 (diagonal swing axle) or with 107 589 02 21 00 (see data) (diagonal swing axle with starting torque compensation).

If the measured value lies beyond the tolerance, vehicle level is adjusted by changing the installation height of the springs (32-200, 32-220).
On vehicles with level control, the vehicle level on the front and rear axle **must** be adjusted, **on principle**, correctly prior to adjusting the control point.

Front lighting system adjust (82-040).

Special tools

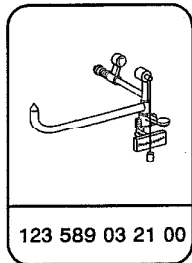

123 589 03 21 00

40-300 Checking vehicle level on front and rear axle

Special tools used up to 07/85

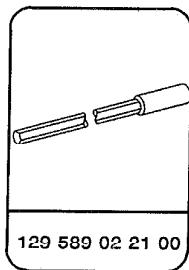
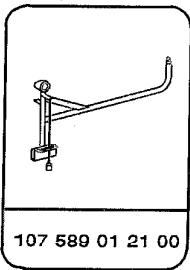

The previously used measuring devices (till 07/85) can be converted using mount 107 589 01 21 12. Thereafter, mark measuring devices with new part number (starting 08/85).

Special tools used after 08/85

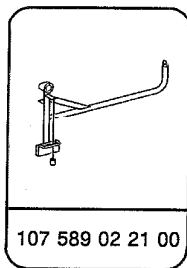
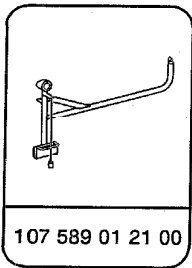

Notes

- The vehicle level is measured in ready-to-drive condition. See general check-ups and prior work regarding chassis alignment check (40-200).
- On principle, check ready-to-drive level on front and rear axle before checking vehicle level.

40-300 Checking vehicle level on front and rear axle

Data

Vehicle level ready-to-drive

Model	Front axle Control arm position mm	Rear axle Vehicle without level control Semitrailing arm position mm	Vehicle with level control Semitrailing arm position mm	Vehicle laden (control point)
-------	--	--	--	----------------------------------

Sedans and Coupes with standard suspension

126.020 126.024 126.025 126.034 126.035 126.046 up to 08/87	45 $\begin{matrix} +10 \\ -15 \end{matrix}$	38 $\begin{matrix} +10 \\ -12 \end{matrix}$	26 $\begin{matrix} +10 \\ -12 \end{matrix}$	8 ± 2 8 ± 10
126.020 126.024 126.025 126.034 126.035 126.046 as of 09/87			31 $\begin{matrix} +10 \\ -12 \end{matrix}$	
126.036 126.037 126.039 126.044 126.045 up to 08/87	45 $\begin{matrix} +10 \\ -15 \end{matrix}$	132 $\begin{matrix} +10 \\ -12 \end{matrix}$	119 $\begin{matrix} +10 \\ -12 \end{matrix}$	101 ± 2 101 ± 10
126.036 126.037 126.038 126.039 126.044 126.045 as of 09/87			125 $\begin{matrix} +10 \\ -12 \end{matrix}$	

Sedans, special version with stiffer suspension for countries with poor road conditions (higher vehicle level)

126.020 126.024 126.025 126.034 126.035	56 $\begin{matrix} +10 \\ -15 \end{matrix}$	49 $\begin{matrix} +10 \\ -12 \end{matrix}$	37 $\begin{matrix} +10 \\ -12 \end{matrix}$	22 ± 5 22 ± 10
126.036 126.037 126.038 126.039		143 $\begin{matrix} +10 \\ -12 \end{matrix}$	130 $\begin{matrix} +10 \\ -12 \end{matrix}$	115 ± 2 115 ± 10

40-300 Checking vehicle level on front and rear axle

Level differences on front and rear axle

Permissible difference of vehicle level measured between left and right side of vehicle	with measuring device	8 mm
	with tape measure	15 mm ¹⁾

¹⁾ Measured vertically from center of wheel to edge of fender well.

Correction of vehicle level

Vehicle level on front axle (control arm position)	Change of front spring rubber mount by 5 mm	provides change of vehicle level (control arm position) by approx. 8 mm
	Change of spring length (replace spring with red color code for blue code or vice versa)	
Vehicle level on rear axle (semitrailing arm position)	Change of rear spring rubber mount by 5 mm	provides change of vehicle level (semitrailing arm position) by approx. 8 mm
	Change of spring length (replace spring with red color code for blue code or vice versa)	